

F2

THE NEXT GENERATION



Certified 650kg CS-23

600kg S-LSA

600kg UL

flightdesign.com



FLIGHT DESIGN LIFTAIR®

Designed for your Mission 3
 Our Mission 3
 Advanced Aerodynamics 4
 Land with Confidence 4
 F2 Safety Cabin..... 4
 Vision Zero 4
 Get comfortable 5
 Firewall forward 5
 Standard equipment 6
 Avionics and Cockpit choices..... 6
 F2-LSA and 600KG UL panel..... 7
 F2 CS-23 Certified IFR panel 8
 Graphic Designs..... 9
 Technical information10

DESIGNED FOR YOUR MISSION

The F2 is the newest aircraft from Flight Design general aviation. One we think will define light aircraft safety, performance and comfort in an EASA CS-23 certified aircraft with an MTOW of 650 kg, or as an SLSA or Ultralight with 600 kg MTOW. The F2 brings a fresh look at high-wing light aircraft design with class leading safety features and an innovative Garmin G3X avionic suite.

The spacious extra-large cabin of the F2 has been designed for increased rigidity and incorporates a combination of dynamically tested passenger seats, panel-mounted AMSAFE™ airbags and an Airframe Emergency Parachute System (AEPS) for your safety. The atmosphere inside the F2 is improved with many clever design features, the modern heating/fresh air system and comfortable leather covered, adjustable seating.

Our Mission



The worldwide flight training industry is looking for new ways to teach more pilots at lower cost, in greater safety and with lower environmental impact. Our mission has been to design the F2 for the demands of professional flight schools and flying clubs as well as private owners who want an easy to fly aircraft with efficiency and cruise performance for true cross-country adventures.

A modern aircraft should have all the features seeking to improve performance, situational awareness and reduce the pilot workload. The F2 includes:

- * Garmin G3X avionics suite with synthetic vision, ADS-B weather, traffic, engine monitoring and maps
- * Single lever throttle and brake system
- * AMSAFE airbags and inertial reel seat belts
- * Dynamically tested, adjustable seats
- * No touch fuel system with electric fuel gauges
- * DLE outer wing optimized for spin resistance
- * Drag reducing sculpted winglets
- * Wide composite main gear
- * Massive center tunnel for cabin rigidity
- * Low drag cowling with easy-to-latch system
- * Heat exchanger heating system
- * Electric trim and pre-selector flap system.
- * Cavernous rear cabin for luggage, bicycles or pets!

The F2 was designed specifically for EASA CS-23 certification and to meet the demanding ASTM F3180 low-speed flight characteristics of fixed-wing aircraft standard for spin resistance and stall warning. Sculpted winglets improve climb and cruising range. The smooth cantilever strutless wing reduces drag and allows maximum visibility from the cockpit.

The sculptured Carbon Fiber fuselage of the F2 is designed for extra-large volume in the cabin and to reduce drag while providing cleaner airflow to the tail. The large span stabilizer and separate elevator have been designed for optimum low speed control and better control feel. In total, the aerodynamic features have significantly improved the F2's stability, control and its overall ease of flying. While the top speed of the F2 is impressively high, the F2 flies with efficiency and low fuel consumption at all speeds. CFD based virtual wind tunnel design tools were used to complete the efficient and refined aerodynamic design.

F2 Safety Cabin

The F2 cockpit has been designed following principles used in the passenger cabins of modern automobiles. Loads are transferred through the passenger area to the crush-zones at the front end of the vehicle. The rigid cabin cell area remains intact while the energy is absorbed in the peripheral areas.

- The rigid engine mount transfers loads into the to the massive attachment to the center structural tunnel.
- The center of the cabin is stiffened with the structural tunnel from the nose gear area to beyond the luggage compartment.
- The area below the seats is reinforced with 'Pyramid structural members installed to the cabin floor, supporting the seats and further stiffening the floor.
- The outer skin is carbon fiber/honeycomb providing maximum stiffness and strength. The suitability of this concept has been improved with data gathered from testing and in service now for 20 years. The service history shows that the cabin concept provides a maximum of occupant protection.

The wide-track composite main gear is extremely rugged while also being flexible, absorbing landing energy and protecting the structure. Urethane polymer shock absorbers in the nose gear give high dampening and help to smooth out hard landings.

The single throttle and brake lever system developed by Flight Design, simplifies power and brake management.



Vision zero

Vision Zero is our mission that zero occupants should face injuries even in a very serious incident. This can be achieved by a combination of passive and active safety systems.

Always pushing forward with new innovations to make flying more enjoyable and safer, Flight Design general aviation has now taken the F2 closer to the ideal of Vision Zero.

A spin resistant airplane with a car-like simplified fuel system, panel mounted airbags, better passenger restraints, and as back-up to those systems an integrated airframe emergency parachute system to protect you and your passenger.

The 1.3 m (51") Extra Large cabin width of the F2 has been designed to fit very tall and smaller people equally well. People with heights of 1.55 to 2.00 m (5' 1" to 6' 6") will sit more comfortably than ever. Ample storage space in the cockpit is provided by great access for bulky items stored aft of the cockpit. Four large cabin windows give the cockpit an open feeling and improve overall visibility.

Large gull-wing doors held up by gas struts make entering and taking your seat easy. Three-point latches and door seals keep you secure inside. The leather covered seats with Confor-foam padding offer comfort for long flights and easy adjustment in height and leg length.

Full dual controls and a centrally located single lever throttle/brake quadrant are features of this ergonomically arranged cockpit. Modern ventilation and heat exchanger heating allow you to fly comfortably in all 4 seasons. The F2 allows up to 40 kg (88 lbs.) of baggage to be safely stored in the giant storage space aft of the cabin area. If you are finding it hard to find an airplane that fits you, try the F2. We think you will be pleasantly surprised!



As a modern and advanced light aircraft, the F2 uses an engine that matches the efficient concept of the airframe, the Rotax™ 912iS. The 912iS offers a high level of sophistication, redundancy and efficiency. With the Flight Design CFD designed split flow cooling systems keeps it cool even in the hottest climates. Oil and Coolant thermostats complete the temperature management and all systems are easily accessible under the easy to remove cowling.

The 912iS fuel injection system precisely controlled fuel-air mixture for dramatically lower CO2 output, improved high altitude performance, more useful torque and improved fuel economy.

- 100-hp Rotax 912iS with fuel injection
- 1352 c.c. 10.5 : 1 compression ratio
- Gearbox: 2.43 : 1 reduction ratio
- Fuel types: Premium unleaded auto fuel or 100 LL Avgas

- BRS Airframe Parachute System
- AMSAFE panel mounted airbags
- Inertial-reel automotive-style seat belts
- Rotax 100 HP 912iS engine
- Stainless exhaust system
- Heat exchanger heat and panel ventilation
- Electric stabilizer trim and pre-selector flap control
- Leather covered sport seats with Confor-foam padding
- Gigantic storage area behind the cockpit
- Extra wide cabin doors with gas springs
- One-piece panoramic windshield
- Two wing tanks with 130 l (34 gallon) capacity
- Electric fuel level gauges
- Composite main landing gear with MATCO hydraulic disc brakes,
- Steerable nose wheel, Wheel pants
- Fire Extinguisher and CO Detector
- A selection of optional graphic patterns
- Complete document package includes: Flight, Maintenance, Transition training and Parts Manual

Flight Design has been in the vanguard of the avionics revolution in light aircraft. With the F2 we offer an expanded range of avionics to suit your personal aviation mission. The F2 features some of the most advanced, yet easy to use avionics from Garmin including the G3X Touch screens for unmatched situational awareness, integration of the Rotax® engine management system, checklists and diagnostic functions.

The bright, high-definition G3X panel includes PFD, EMS and Map functions with a battery back-up. With the Garmin GTX 345 transponder the F2 is compliant with the FAA's ADS-B 2020 "Out" requirements and has the complete ADS-B "in" features like Satellite based weather, traffic and real-time TFR notices. Depending on your needs, an additional navigation source can be provided by optional GNC 255 Nav/Com or a Garmin GTN 650. The Garmin GFC 500™ Digital 2-axis autopilot with Level Button rounds out this well-balanced avionic suite.



1	Garmin G3X GDU 460 Screen (10.6" landscape format)
2	AMSAFE pilot and passenger Airbags
3	GTR 225A com or 255 Com-Nav-com
4	Optional Heated Pitot Probe switch
5	Garmin G5 backup system
6	Garmin GMC 507 Digital autopilot "mode controller panel"
7	Artex 345 ELT 406 MHz with remote control
8	GMA-342 stereo audio panel
9	Garmin 345 ADS-B "in and out"
10	Fresh air and heating vents



1	Garmin G3X GDU 460 Screen (10.6" landscape format)
2	AMSAFE pilot and passenger Airbags
3	GTC 255A Com-Nav radio
4	Garmin GMAT™ 35c remote stereo audio panel (unit installed inside instrument console)
5	Garmin GTN 750 GPS Navigator
6	Garmin GTX 345R ADS-B 'In and Out' remote mount transponder (unit installed inside instrument console)
7	Garmin G5 backup system
8	Garmin GMC 507 Digital autopilot 'mode controller panel'
9	KANNAD INTEGRA AF 406 ELT 406 MHz with remote control
9a	Artex 345 ELT 406 MHz with remote control
10	Fresh air and heating vents
11	Traffic Monitoring Function (unit inside instrument console)
12	Optional Heated Pitot Probe switch



ORACAL 951 series		070	Black
ORACAL 951 series		090	Silver grey
ORACAL 951 series		032	Light red



ORACAL 951 series		049	King Blue
ORACAL 951 series		090	Silver grey
ORACAL 951 series		052	Azure Blue

The colors reflected on the brochure are only approximations of the original colors.

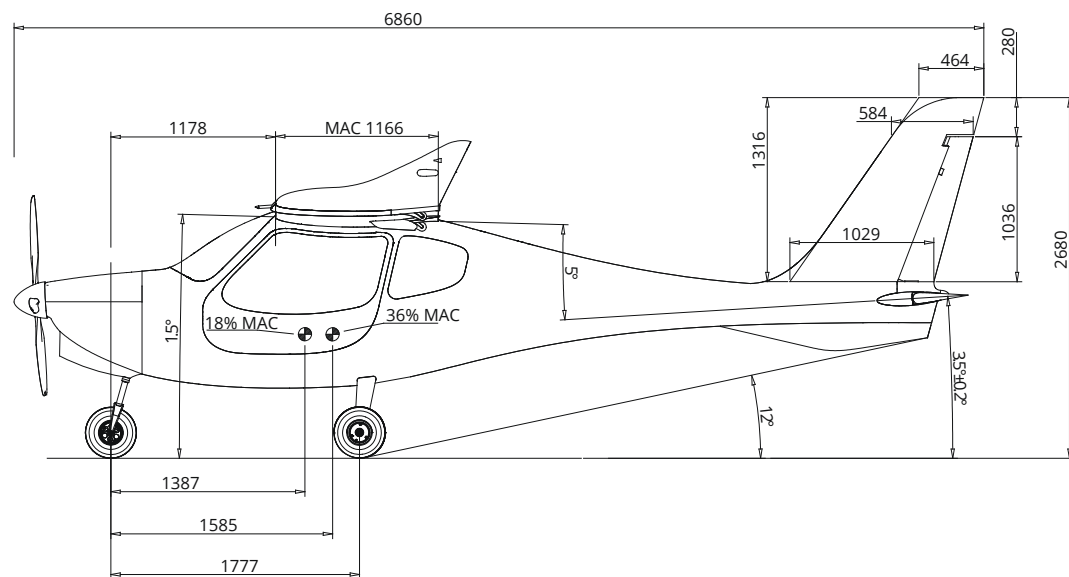
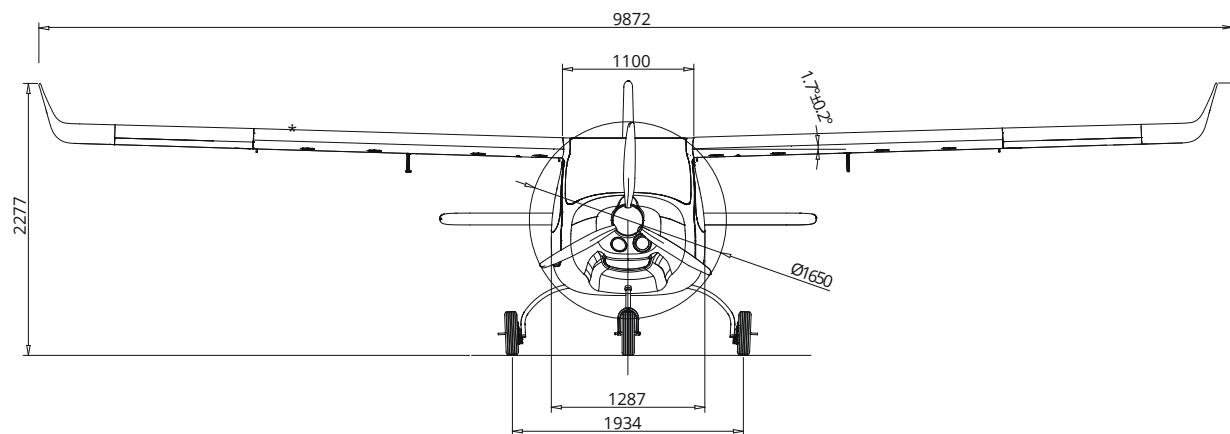

SUMMARY OF PERFORMANCE SPECIFICATIONS

Maximum tested gross weight	650 kg (1433 lbs.)
Total fuel capacity	130 l (34.3 gal)
Approved Fuel – Premium Automotive unleaded	91Avgas -100 LL Avgas
Maximum engine power	73.5 kW (100 hp) @ 5800 rpm
* Range, full fuel, with 30 min reserve up to 1.000 NM = 1850km)	
* Maximum speed 136 kts (252 km/h) TAS at 5800 rpm at 7500 ft	
* Cruise speed 126 kts (233 km/h) TAS, at 75% power (5200 rpm) at 7500 ft	

* Projected and to be confirmed by flight testing

**F2 Dimensions
Main Dimensions:**

Wing span	9.872 m (32.3 ft)
Length	6.86 m (22.50 ft)
Height	2.34 m (8.75 ft)

Wings:

Airfoils FD 144-44 inboard, FD 144-42 outboard
Wing area 11.1 sq. m (120 sq. ft)
Aspect ratio 8.7
Mean Aerodynamic chord (MAC) 1.166 m (3.83 ft)

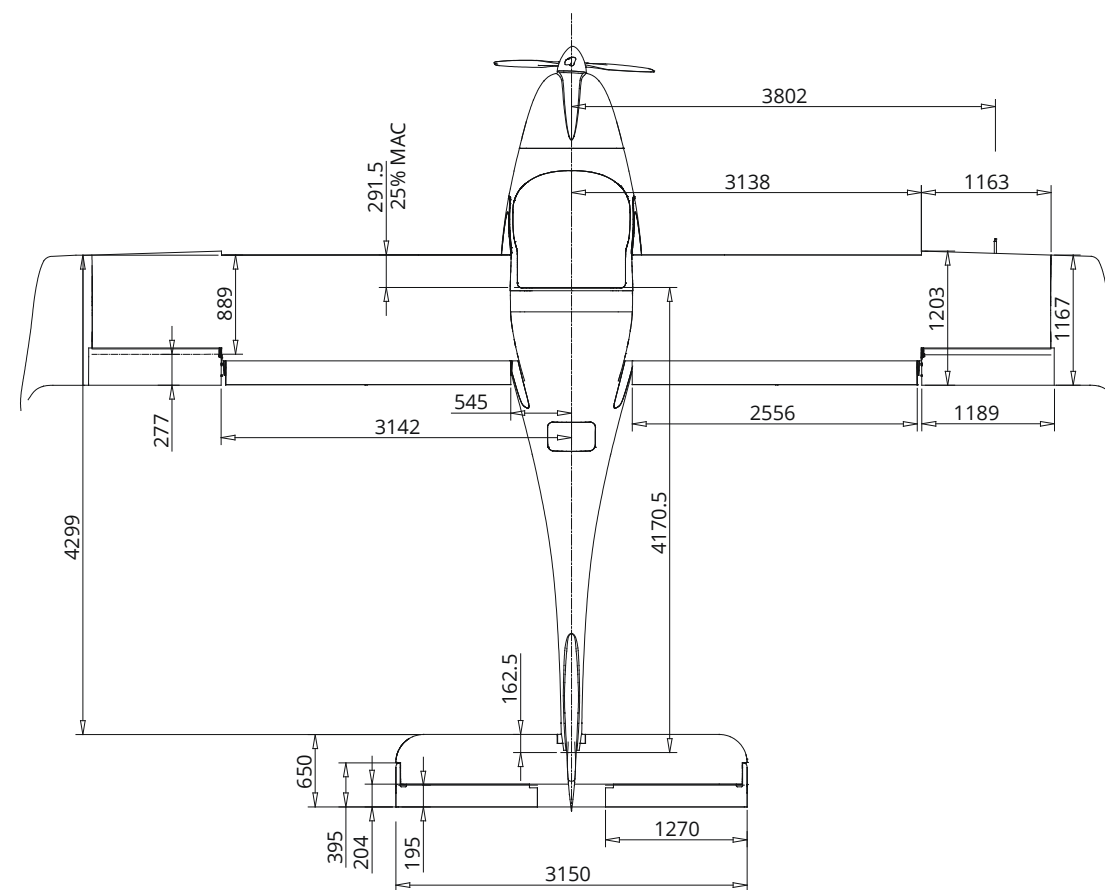

Horizontal Tail

Area	2.05 m ² (22.04 ft ²)
Span	3.15 m (10.33 ft)

Cabin Width 1.29 m (50.5 inches)
Maximum Takeoff Weight (MTOW): 650 kg (1433 lb.)
Basic Empty Weight 374 kg (824 lb.)

